

Paolo Pizzani

All for company (omaggio a Beckett)

Cantata scenica su testi di Samuel Beckett
per tre voci femminili

a Gabrielangela

I Company (frammento)

Pss

II Something there

III Roundelay

IV What is the word

1 – soprano

2 – soprano

3 – mezzosoprano

R – voce registrata

Le tre cantanti vestono abiti da sera neri, il più possibile simili

Facce bianche (non eccessivamente)

Lights:

L. a = music-stand light + light from on high

L. b = music-stand light + light from on high

L. c = music-stand light + light from on high

L. d = music-stand light + light from on high

L. busto b,c,d = music-stand lights + light only on the bust's singers

L. e = music-stand light + light from on high

L. a2 = music-stand light (with potentiometer)

L. c2 = music-stand light (with potentiometer)

L. e2 = music-stand light (with potentiometer)

L. x = diffused half-lighting

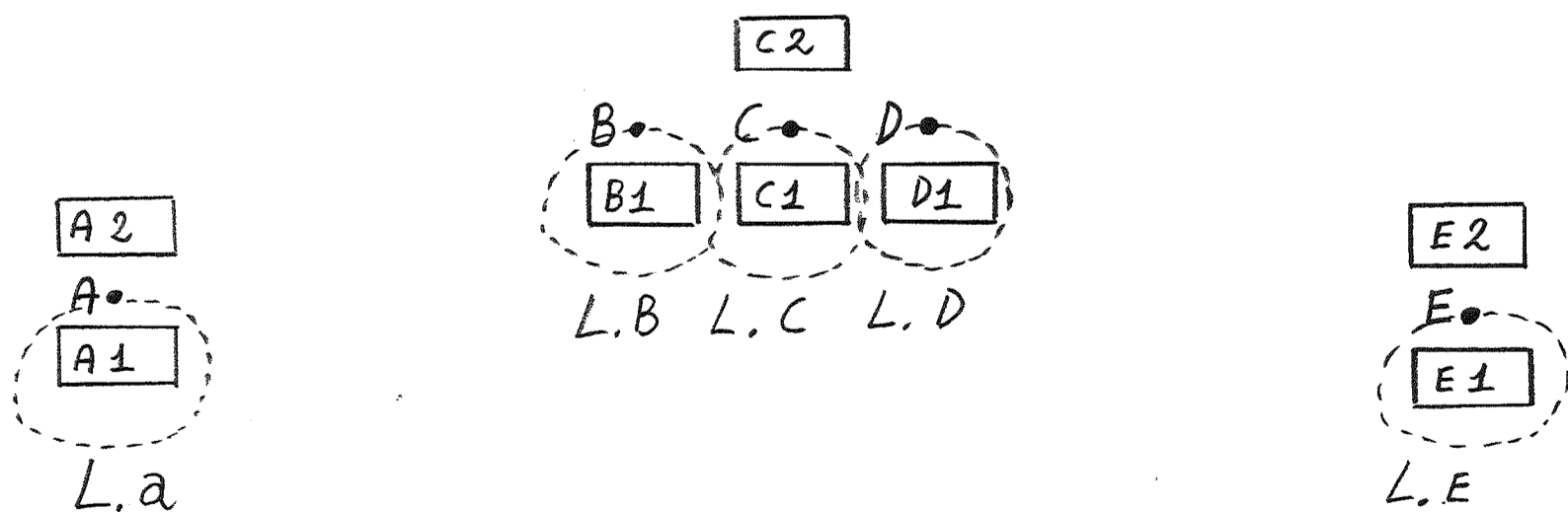

Segni e avvertimenti



= Parlato. Le note indicano le variazioni di "intonazione" della prosodia.

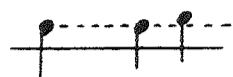

= quando da una nota parte una linea tratteggiata, quest'ultima vale da punto di riferimento per l'intonazione prosodica dei suoni successivi.



= sussurrato, senza adduzione delle corde vocali



= mormorato, con adduzione delle corde vocali e minimi movimenti delle labbra.

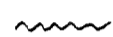

= ribattuto (staccato) di gola. Cantare eseguendo un "trillo" strettissimo sulla stessa nota, come ridendo. Si pensi al grido di un uccello



= battere velocemente e leggermente la mano contro le labbra, come un trillo.



= soffio intonato. Quasi un fischio.



= colpo di glottide, quasi come tossendo



= inspirare: senza addurre le corde vocali si assuma la posizione della bocca come per pronunciare il suono indicato

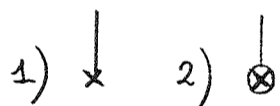

= battito delle mani:

- 1) indice e medio di una mano contro il palmo dell'altra
- 2) indice, medio, anulare e mignolo di una mano contro il palmo dell'altra

Diesis e bemolle alterano solo la nota davanti alla quale sono posti (tranne nel caso di suoni immediatamente successivi)

Quando seguite da tre punti le indicazioni valgono sino alla indicazione successiva

note sulla pronuncia dei suoni:

$S_{(a)}$ $Z_{(a)}$ ecc. = la vocale posta tra parentesi indica la posizione che le labbra e la lingua devono assumere nel pronunciare la consonante "sorda" che la precede

$\underset{\cdot}{S}$ $\underset{\cdot}{Z}$ ecc. = il punto sotto la consonante indica un' esecuzione "sonora" (con adduzione delle corde vocali, e dunque "intonata") e non "sorda".

- $\underset{\cdot}{a}$ = it: casa, ingl: father, ted: Wasser
- $\underset{\cdot}{b}$ = it: bello, ingl: bed, ted: bar
- $\underset{\cdot}{c}$ = it: bacio, ingl: church, ted: Mädchen
- $\underset{\cdot}{d}$ = it: dente, ingl: day, ted: da
- $\underset{\cdot}{e}$ = it: seme, ingl: day, ted: lesen
- $\underset{\cdot}{f}$ = it: bello, ingl: and, fr: misère, ted bitte
- $\underset{\cdot}{g}$ = it: fiore, ingl: fat, ted: Fass
- $\underset{\cdot}{h}$ = it: gatto, ingl: give, ted: Gegend
- $\underset{\cdot}{i}$ = ingl: hang, ted: Harr
- $\underset{\cdot}{j}$ = it: pino, ingl: yes, ted: ja
- $\underset{\cdot}{k}$ = it: poco, ingl: car, ted: Kant
- $\underset{\cdot}{l}$ = it: lingua, ingl: look, ted: Lied
- $\underset{\cdot}{m}$ = it: mamma, ingl: much, ted: Mutter
- $\underset{\cdot}{n}$ = it: notte, ingl: never, ted: Name
- $\underset{\cdot}{o}$ = it: notte, ingl: box, ted: hoffen
- $\underset{\cdot}{p}$ = it: sotto, ingl: ball, ted: oben
- $\underset{\cdot}{r}$ = it: pino, ingl: pot, ted: Pol
- $\underset{\cdot}{r}$ = it: raro, ted: Rat
- $\underset{\cdot}{s}$ = it: sera, ingl: see, ted: Sessel
- $\underset{\cdot}{s}$ = scena, ingl: show, ted: schön
- $\underset{\cdot}{t}$ = it: tetto, ted: Tier
- $\underset{\cdot}{u}$ = it: muto, ingl: book, ted: Mut
- $\underset{\cdot}{v}$ = it: vaso, ingl: very, ted: Wasser
- $\underset{\cdot}{z}$ = it: zucchero, ingl: hints, ted: Zimmer

NB: le parole o le sillabe sottolineate vanno pronunciate in lingua inglese

All for company (omaggio a Beckett)

Cantata scenica su testi di Samuel Beckett
per tre voci femminili

v.1 = posizione C (faccia al pubblico)

v.2 = posizione D (faccia al pubblico)

v.3 = posizione E. (volto rivolto verso la sua destra. Sguardo lontano, poco più alto rispetto all'orizzonte)

(calmo, con intento comunicativo)

mf subito

(Buio)

R Till finally you hear how words are coming to an end.

2"
⌒

(più lento, meditativo)

mp

R With every inane word a little nearer to the last

6"
⌒

(più veloce)

mp

R And how the fable too:

10"
⌒ (dopo 5": Lento crescere (5")
di L.x (tenue)

(stessa velocità della frase precedente)

p

R The fable of one with you in the dark.

15"
⌒ (dopo 2": dissolvenza lenta (5")
di L.x
(Buio)

(più veloce e stringendo ancora)

p

R The fable of one fabling of one with you in the dark.

20"
⌒ (dopo 15": Lento crescere (5")
di L.x (tenue)

(molto veloce ma rallentando)

mp

R And how better in the end labour lost and silence.

3"
⌒

rallentando ancora

p

R And you as you always were.

*

* La successiva, e ultima, parola registrata ("Alone") verrà detta durante la corona di battuta 2.

PSS

Mosso (♩=85 c.a)

(dopo 2": dissolvenza) lenta (5") di L.X Buio

(dopo 15"): R **Alone** (poi: lento crescere (5") di: L.C, L.D, L.E (tenui))

P (calmo)

Calmo (♩=60 c.a)

(subito L.C, L.D, L.E più forti)

Tempo I

cedendo

* L'attacco deve avvenire un istante dopo la pronuncia dell'inizio della penultima parola registrata ("were.")

** mormorato, veloce. L'attacco della voce 1 deve avvenire prima della conclusione della frase, interrompendola. Sicerchi comunque di arrivare a pronunciare l'inizio dell'ultima parola ("dark.")

subito
Tempo I

di nuovo cedendo

7

p *pp* *p* (corta) *pp* *p* *o* *<p>* *<mp>* *<pp>* *<pp>*

p *p* *<pp>* *p* *<pp>* *<p>* *<pp>* *<pp>*

molto

Calmo (♩=60 c.a)

10

pp *pp* *pp* *sf*

pp *pp* *pp* *p*

15''

m m

(deciso)
ff (-)

There

subito Tempo I

13

Musical score for measures 13-15, consisting of two staves. The music is in 3/4 time and features complex rhythmic patterns with triplets and sixteenth notes. Dynamic markings include *sf*, *f*, *ff*, *p*, and *sf*. Performance instructions include *i...* and *m...*. The score is divided into three measures by vertical dashed lines.

cedendo - - - - -

16

Musical score for measures 16-18, consisting of two staves. The music continues with complex rhythmic patterns and triplets. Dynamic markings include *ff*, *sf*, *f*, *mf*, *mp*, *p*, and *pp*. Performance instructions include *(deciso)* and *(calmandosi)*. The score is divided into three measures by vertical dashed lines.

a poco

a poco

19

(m)... a (m) a (m) a (m) ♯ (m) a (m) a (m) ♯ E (m) ♯ a

(m)... E (m) E (m) E (m) ♯ E (m) E ♯ (m) b ♯

riprende
Calmo (♩ = 60 c.a)

22

(m) a (m) (m) E a ♯ a

♯ (m) E (m) E a (m) a (m)

(subito faccia al pubblico)
subito deciso (Tempo I)

the live late led

25

subito
Tempo I

rall.---

Musical score for measures 25-28. The score is written for three staves: a vocal line (top), a piano accompaniment (middle), and a bass line (bottom). The music includes various notations such as triplets, slurs, and dynamic markings like *sf*, *mf*, *pp*, and *mp*. The lyrics "down there" are written below the bass line.

molto

Più Calmo (♩=50 c.a)

28

Musical score for measures 28-31. The score is written for three staves: a vocal line (top), a piano accompaniment (middle), and a bass line (bottom). The music includes various notations such as triplets, slurs, and dynamic markings like *p*, *mp*, *pp*, and *f*. The lyrics "all done un-said" are written below the bass line.

31

p pp p

i i pp

34

pp $<p>$ $<p>$ $<p>$ $<pp>$

i i $i...$

pp $<p>$ $<p>$ $<pp>$

i i $i...$

$<mf>$

a-gain gone

37

pp *p* *mp* *p* *pp* *mf* *sf* *mp*

subito
Tempo I

pp *p* *mp* *p* *pppp...* (*pppp*) *pp* *f* *f*

(si gira lentamente verso v.1 e v.2)

mp

with what to tell

40

di nuovo
Almo (♩=60 c.a.)

pp *p* *mf* (d.)

sf *pp* *p* *pp*

(subito faccia a pubblico)
(subito piú presente)
mf (—)

p *p*

on a-gain re-tell

43

Musical score for measure 43. The system consists of three staves. The top staff is a vocal line with lyrics "i i". The middle staff is a piano accompaniment with a triplet of eighth notes marked *pp* and *vibr*. The bottom staff is another vocal line with lyrics "hea- d oh ha-". It features a triplet of eighth notes marked *pp* and *poco vibr*, followed by a quarter note marked *sf* and *(p)*, and another triplet marked *pp* and *(non vibr)*.

46

Musical score for measure 46. The system consists of three staves. The top staff is a vocal line with lyrics "m i i m...". It includes a triplet of eighth notes marked *pp*, a quarter note marked *p*, and another triplet marked *pp*. The middle staff is a piano accompaniment with triplets of eighth notes marked *pp*, *p*, and *sf*. The bottom staff is another vocal line with lyrics "- m - ds S(i) S(u) m m". It features a quarter note marked *p*, a triplet marked *sf* and *(p)*, and another triplet marked *pp*.

49

Musical score for measures 49-51. The top staff features a whole note with a wavy line, marked *mf*. The middle staff contains a melodic line with eighth notes, marked *m* and *p*. The bottom staff has a melodic line with eighth notes, marked *pp*. The score includes slurs, ties, and dynamic markings.

rall.

52

Musical score for measures 52-54. The top staff features a melodic line with eighth notes, marked *mp*, *p*, *sf*, *p*, *f*. The middle staff contains a melodic line with eighth notes, marked *mp*, *mf*, *mp*, *p*, *pp*, *ppp*, *sf*. The bottom staff has a melodic line with eighth notes, marked *m...*, *2 (c)*, *m...*. The score includes slurs, ties, and dynamic markings.

Più Calmo (♩=50 c.a)

55

p *p...* *(p)*

m *m* *f*

hold me

58

subito
Tempo I
(subito si gira verso v.3)

sff *f* *mf* *p* *p*

(subito si gira verso v.3)

mf... *poco rit* *accel.* *sff* *f* *mf* *p* *pp* *mp*

m... *m...*

(subito si gira verso v.1 e v.2)

f

un-clasp

Dissolvenza lenta di L.c, L.o, L.e (il buio è raggiunto a b. 65)

rall. (calmo)

(ritorna lentamente con faccia al pubblico)

61

(ritorna lentamente con faccia al pubblico)

(ritorna lentamente con faccia al pubblico)

(ritorna lentamente con faccia al pubblico)

(buio)

ancora cedendo - - - - - molto

(abbassando lentamente la testa)

64

(va in posizione A, faccia al pubblico)

(va in posizione C, faccia al pubblico)

(rimane in posizione E, faccia al pubblico)

hold me

Something there

[lento crescere (10") di L.A, L.C, L.E]

10"

Virace (♩ = 95 c.a)

Handwritten musical score for the first system of 'Virace'. It consists of three staves in 3/4 time. The music is marked with a piano (*P*) dynamic and features a series of rhythmic patterns. The notes are annotated with various articulation and fingering symbols, including $S_{(i)}$, $S_{(u)}$, $S_{(u)}^{(i)}$, and $I_{(o)}$. The score is divided into four measures, with the final measure ending with a double bar line and a fermata.

5

Handwritten musical score for the second system of 'Virace', starting with a boxed measure number '5'. It consists of three staves in 3/4 time. The music features dynamic markings such as *mp*, *pp*, *mf*, and *pp* (subito). The notes are annotated with articulation and fingering symbols, including $I_{(o)}$, $h(o)$, $S_{(u)}$, $S_{(u)}^{(i)}$, and $S_{(u)}^{(i)}$. The score is divided into four measures, with the final measure ending with a double bar line and a fermata. Additional markings include *(sempre) (pp)* and *(pp) (sempre)*.

9

Musical score for system 9, measures 1-4. It features three staves with vocal lines and piano accompaniment. Dynamics include *p*, *pp*, and *pp...*. The notes are: *So* *o* *So* | *So* *o* *o* *So* *o* | *So* *o* *o* *So* *So* *o* | *a* *a* *So* *So*.

13

Musical score for system 13, measures 1-4. It features three staves with vocal lines and piano accompaniment. Dynamics include *p*, *pp*, and *pp...*. The notes are: *So* *a* *o* *So* *So* *a* | *a* *o* *o* *o* *a* | *a* *a* *a* *a* *ε* *ε* | *Sa* *ε* *ε* *Sε* *ε* *ε*.

accelerando - - - - - (♩=105 c.a)

17

(pp) cresc. - - a poco - - a poco - - - - - p

(pp) cresc. - - a poco - - a poco - - - - - p

(pp) cresc. - - a poco - - a poco - - - - - p

SE E E... S(i) S(i) SE E S(i) S(i) SE S(i)

E E SE E E E E E r... S(i) r... S(i) S(i) r

E SE E E... r... S(i) S(i) Se r S(i) S(i)

accel. - - - - - Agitato (♩=120 c.a)

21

P - - - - - (f) - - - - - ff... sf f

P - - - - - f - - - - - ff... p f

P - - - - - f - - - - - p subito p ff

S(i) SE S(i) S(i) r Se Se S(i) Si S(i) S(i) Si Si Some-thing h(e) out
-thing there (sempre) out

S(i) S(i) Se S(i) r S(i) Se S(i) S(i) si i i S(i) S(i) si si si si Some-thing i out
-thing there

r S(i) r S(i) S(i) Si i S(i) i S(i) S(i) Si i i i S(i) Si Si i i where

25

2 3 2 3 3

sf *p* *mf* *f* *f* *p* *mf* *p...*

there *i* *i* out-side *i* some-thing there some-where out-

sf *p* *mf* *p* *mf* *mp* *pp...* *p...*

there *h(e)* (sempre) *i* out-side *i i i* the head what else *i i* some-thing there some-where out-

p *mf* *sf* *p* *f* *pp* *p* *mp* *pp...*

i i out where *i i i* what *i i* Some-thing there

un poco rall.

31

f *p* *pp* *pp* *pp* *pp* *pppp...*

-side *h(u) h(u) h(u)* *h(u) h(u)* *h(u) h(u) h(u) h(u)*

pp *ppp* *pp* *mf* *pp* *ppp* *pp* *pppp...* *ppp*

-side *h(u) h(u)* *h(u) h(u) h(u) h(u)* *h(u) S_(u)⁽ⁱ⁾*

p *mp* *f* *pp* *p* *ppp* *pppp...* *ppp* *pppp*

the head *h(e)* (sempre) *h(u) h(u) h(u)* *h(u) h(u) h(u) h(u)* *h(u) S_(u)⁽ⁱ⁾ h(u) h(u)*

Animato ($\text{♩} = 110 \text{ c.a.}$), *meccanico, preciso, senza rallentare*

35

pp...

the faint so brief it gone and whole globe yet

pp...

at the sound so brief is gone the whole not yet

pp...

at faint sound it is and the globe not

40

mp pp pp

bare the eye *h* -pens wide wide till end ha → ho

mp pp p mp

h o-pens wide till in *mp*

mp p mp pp

bare the eye o- wide wide in the end *mp*

ppp...

45

Musical score for system 45, measures 45-48. It features three staves with lyrics: "no- more", "no- thing", "- thing more", "shu- it a- gain", "shu-tters a- gain", and "so". Dynamics include *pp*, *mp*, *p*, and *f*. There are also performance markings like "2(u)", "3", and "PP x (sempre)".

49

Musical score for system 49, measures 49-52. It features three staves with lyrics: "the odd time out there some-where out there like as if", "the odd time", "some-where out there", and "the odd time some-where out there". Dynamics include *p*, *mp*, *(pp)...*, and *f*. There are also performance markings like "2", "3", and "PP (sempre)".

(NB: 2" dopo la fine:
buto subito)

stringendo - - - - - molto

54

The musical score consists of three staves. The top staff (V.1) has lyrics: "something not life me - cessarily". The middle staff (V.2) has lyrics: "as if S(i)... not life me - cessarily". The bottom staff (V.3) has lyrics: "h(o)... me - cessarily". The score includes various musical notations such as dynamics (p, mp, mf, pp), accents (>), and slurs. There are also some handwritten annotations like "S(i)" and "h(o)".

- V.1 va in posizione B (faccia al pubblico)
- V.2 va in posizione D (faccia al pubblico)
- V.3 va in posizione C (faccia al pubblico)

Roundelay

[subito L. BUSTO B,C,D]

Parlante (♩ = 52 c.a)

10"

Musical score for the first system of 'Roundelay'. It consists of three staves. The top two staves are empty. The bottom staff contains the vocal line with lyrics: "on all that strand at end of day steps sole sound long sole sound". Above the staff, there are four boxed measures: 4/4, 3/4, 4/4, and 3/4. Dynamic markings include *mp*, *p*, *mf*, and *p*. There are also slurs and accents over the notes.

Musical score for the second system of 'Roundelay'. It consists of three staves. The top two staves are empty. The bottom staff contains the vocal line with lyrics: "until unbidden stay then no sound on all that strand". Above the staff, there are four boxed measures: 5/4, 3/4, 2/4, and 2/4. The tempo markings are *rall*, Più calmo (♩ = 45 c.a), and Tempo I. Dynamic markings include *p*, *ppp*, and *mp*. There are also slurs and accents over the notes.

9 4 5 *rall.*

P *pp* *P* *PPP* *pp* *P*

long no sound until unbidden go steps sole sound

12 4 5 4 *Più calmo* ($\text{♩} = 45 \text{ c.a.}$) *e cedendo ancora* (V.1 si avvicina a V.3)

mp *p* *pp* *PPP* *pp*

long sole sound on all that strand at end of day

21

riprende
tempo Scorrere (♩ = 60 c.a.)

(these no sound)

rall.

ε h(o) i h(o) i

h(o) h(o) i

(i) r h(u) h(o) i i

24

riprende
tempo Scorrere (♩ = 60 c.a.)

(on all that strand) 5

(long no sound) (until unbidden go)

rall.

i h(o) m ε h(o) m m m

h(o) → (o) S(i) h(o) h(u) S(u) S(o) S(i)

(s) S(i) S(i) S(i) S(i) S(i) S(i)

un poco piú lento ($\text{♩} = 55 \text{ c.a.}$)

p (steps sole sound) *P* (long sole sound)

27 3

(S_i) → Z_(i) $\check{C}(i)$ S_(i) m $\check{C}(i)$ $\check{I}(o)$ S_(i)

cedendo ancora *piú calmo* ($\text{♩} = 45 \text{ c.a.}$)

4 3 (on all that strand) 5 (at end of day)

31

S_(i) → S_(u) → S_(i)

S_(i) h_(o) → (o) S_(i)

(pp) = p mp p

S_(i) → (u) I_(o) i m

34

4

(at end of day)

5

3

PP

(sim.)

$S(u) \rightarrow S(i)$

(PPP)

(o)

3

PP

3

$S(i) \rightarrow S(u)$

7

3

7

3

m

37

(on all that strand) (at end of day) (at end of day)

9

3

3

P

PP

3

3

7

3

h(o)

m

$S(u) \rightarrow S(i)$

S(i)

S(i)

S(i)

PPP...

(o)

3

P

P

7

3

7

3

$S(i) \rightarrow h(o) \rightarrow (o)$

3

PP

vibr. molto

3

3

7

3

7

3

l(u)

m

i

[dissolvenza lenta di L. BUSTO B, C, D]
 (il buio è raggiunto a b. 46)

ceolendo - - - - -

(ppp) $\overset{\circ}{\curvearrowright}$

(on all that...)

(at end of day)

(Sii) \rightarrow S(v)

h(o)

S(v) \rightarrow S(i)

Z(i)

m

i \rightarrow r

S(o)

on all that strand

at end of day

(buio)

(pp) $\overset{\circ}{\curvearrowright}$

(pp) $\overset{\circ}{\curvearrowright}$

(ppp) $\overset{\circ}{\curvearrowright}$

(pp) $\overset{\circ}{\curvearrowright}$

(S(o)) \rightarrow S(i)

V.1 va in posizione A,
 spalle al pubblico

V.2 va in posizione C,
 spalle a pubblico

V.3 va in posizione E,
 spalle al pubblico

What is the word

Veloce e deciso ($\text{♩} = 125 \text{ c. a.}$)

10" [dopo 5":
lento crescere (5")
Luce leggjo c2]

4/4 *sf* (gridato) (con v. 2) 2/12 *sf* 4/4 *sf* 5/4

folly i

folly for to folly from this

(con v. 2) (gridato) for to what is the word all this

5 [subito Luce leggjo E2]

3/4 *sf* [subito Luce leggjo A2] 5/8 *sf* stringendo 4/4 *sf* [subito Luce leggjo E2]

given given seeing

folly from all this folly given all this

seeing

subito Tempo I (♩=125c.a)

9

Musical score for measures 9-14. The score is written on three staves. Measure 9 is marked with a boxed '9' and a '2/4' time signature. Measures 10-11 have a '2/12' time signature, and measures 12-14 have a '3/4' time signature. The music features various dynamics including *sf*, *ff*, and *ff...*, along with accents and slurs. The lyrics are: seeing *i...* this this this this folly given all folly seeing all this this this here this here given all seeing this what is the word all this this here

15

Musical score for measures 15-18. The score is written on three staves. Measure 15 is marked with a boxed '15' and a '2/12' time signature. Measures 16-17 have a '3/4' time signature, and measure 18 has a '3/8' time signature. The music includes dynamics such as *sf*, *ff*, *pp*, *p*, *mp*, and *ff*, along with accents, slurs, and the instruction *corta*. The lyrics are: this seeing folly seeing all this this here this seeing all this this here seeing a... seeing a this here for to

[crescono (in 3'') L.A, L.C, L.E]

(lentamente si gira: faccia al pubblico)

20

i...

i...

a...

(lentamente si gira: faccia al pubblico)

(lentamente si gira: faccia al pubblico)

Più Veloce (♩=130 c.a.)

23

see seem to

what is the word a... glimpse

what is the word a...

28

glimpse glimpse folly for to need to seem to glimpse what is the word

glimpse need to seem to glimpse need to seem to glimpse what is the word

for to a... glimpse

mp ff mf ff sf

2/4 2/12

(senza rallentare!)

32

and folly for to to see to glimpse where

where need to see to glimpse what where what is the

and E E need see to glimpse what where what is the

pp p pp p mp f

3/4 2/4 3/8

torna Tempo I (♩=125c.a)

38 3/4 4/4 3/8

p *f* *p* *mf...* *f* *mp*

ff *p* *f* *mf...* *mf* *p*

ff *ff* *mf...* *mf*

word *i* word *i* word there over there E...

42 4/4 5/4 2/12 1/8 2/4

f *mf...* *mf* *p* *f* *mf...* *ff...* *ff...*

f *mf...* *mp* *f* *mf* *ff* *ff...*

f *mf* *mf* *f* (subito) *(f)* *ff...* *sf* *ff...*

a over i i -> e a-far a-way over there a-faint a-far

a-way over there i -> e a-far away over there a-faint a-

away over there afar away over there E... E...

47 3/4

over there what is the word *i* *i* -> *e* *e* -> *i* seeing all this *i* ->

way what what is the word *i* *i* -> *e* *e* -> *i* all this *i* ->

what *E*... *O*... *E* *e* *o* *o* *i*

accel. - - - - -

51

all this this *i*... *e*... *e* all here fo-llly for to see

E *E* *e* *i* -> *e* -> *i* *e* *e* *e* -> *E* this here fo-llly for to see

E... *O*... *E* *o* *e* *o* this fo-llly for *o* *o* to see

Più veloce (♩=130c.a)

subito
Tempo I
(♩=125c.a)

54

3/4 4/4 3/8 3/4

sf *sf* *sf...* *sf* *mp...*

what glimpse seem to glimpse

sf *sf* *sf...* *sf* *mp...*

what glimpse *ε...* seem to glimpse

sf *f* *sf* *sf...*

what *ε* glimpse *ε...* seem to glimpse

p *p* *p*

p *p* *p*

vibr. *vibr.*

58

4/4 3/4 4/4

(mp) *f* *mp* *f* *mf...* *f*

mp *f* *mp* *f* *mf...* *sf* *mf...*

pp... *vibr.* *(pp)* *mf...* *f*

vibr. *vibr.*

need need need

i...

62

3/4

mf < f > mf < f > 3

3/4

f < p < f > vibz

to seem to glimpse ε ε i...

f < p < f > p > mp > 3 f < p < f > p < f > p < f > p

to seem to glimpse ε e i i...

mf < f > p < f > p mp mp 3 f

to seem to glimpse ε ε e e e i i i

string. - - - - - molto - - - - - subito
Tempo I (♩=125 c. 2)

66

4/4

f... 3 3 3

3/4

3

4/4

f < p < f > f

f... 3

f... p sf p 3

i...

70

ff mp... f mp... f mp f mp

i i a-faint e e ε → e e a-far a a ε → e a-way over there what a-faint a-far

ff mp... f mp... mp f mp

i i i a-faint e e ε → e a-far a a a-way over there what a-faint e e a-

ff mp... (mp) f mp

i i i a-faint a-far a a a-way over there what a-faint e e ε → e e

74

f p ff p pp

a a a-way over there what a-faint a-far a way over there what ε → i folly for to need to seem to glimpse a-

f p ff p pp

far a a a-way over there what a-faint a-far a-way over there what ε → i folly for to need to

f p ff pp

a-far a a-way over there that a faint a-far a-way over there that folly for to need to glimpse a way over to seem a faint a far

3/4

77

ff P pp ff... sf

faint afar away over there that folly for to need to glimpse a faint afar away over there what

seem to glimpse afar away over there what folly for to need to glimpse a faint afar away over there what i... what

there what folly for to need to seem to glimpse a faint afar away over there what

4/4

3/4

80

f... vibr. ff... <sf> sf> f ff ff

f... vibr. <ff> ff... sf> f ff ff

f <ff> f sf sf> sf> sf> ff

un poco rallentando

84

ff *ppp* *P* *pp*

(d.)

ff *ppp* *P* *pp*

(d.)

ff *P* *P* *pp*

(sim.)

what is the word

i *R* *m* *R* *E* *R* *i*

più calmo (♩=100 c.a) *di nuovo accelerando*

87

P *pp* *pp* *pp* *pp*

pp... *(P)* *pp* *pp* *pp*

m... *m* *m* *m*

molto tempo Più Veloce (♩=130c.a)

90

Musical score for measures 90-92. The score consists of three staves. The first staff begins with a treble clef and a key signature of one flat. It contains a melodic line with triplets and dynamic markings: *pp*, *pp*, and *ppp...*. The second staff continues the melodic line with similar dynamics and includes a fermata. The third staff provides a harmonic accompaniment with triplets and a dynamic marking of *m*. Vertical dashed lines separate the measures.

93

Musical score for measure 93. The score consists of two staves. The first staff has a treble clef and a key signature of one sharp. It features a melodic line with triplets and dynamic markings: *<P>* and *ppp...*. The second staff continues the melodic line with triplets and a dynamic marking of *(m)*. Below the staves, the instruction *(liberamente, mormorando)* is written. At the bottom, the lyrics "what is the word" are written under a long horizontal line with a dynamic marking of *P* and a triplet bracket above it.

(liberamente, mormorando)

P

what is the word

torna a

Tempo I (♩=125 c.a)

96

5
4

4
4

Musical score for measures 96-98. It consists of three staves. The first staff has a treble clef and a key signature of one sharp (F#). It features a melodic line with triplets and dynamic markings: <P>, <mp>, mf, pp, and mf. The second staff has a treble clef and a key signature of one flat (Bb). It features a melodic line with triplets and dynamic markings: <P>, pp, <mp>, pp, mf, f, pp, mf, mf. The third staff has a bass clef and a key signature of one flat (Bb). It features a bass line with dynamic markings: <mp>, pp, mf, mf, P, pp, mf. Measure numbers 5 and 4 are written above the first staff. A boxed measure number 4 is written above the second staff. Vertical dashed lines separate the measures.

99

Musical score for measures 99-101. It consists of three staves. The first staff has a treble clef and a key signature of one sharp (F#). It features a melodic line with triplets and dynamic markings: mf, mf, mf, f, P, f, f. The second staff has a treble clef and a key signature of one sharp (F#). It features a melodic line with triplets and dynamic markings: mf, mf, ff, f, P, f. The third staff has a treble clef and a key signature of one sharp (F#). It features a melodic line with dynamic markings: P, mf, f, P, ff, P, f. Measure numbers 99, 100, and 101 are written above the first staff. Vertical dashed lines separate the measures.

102

ff pp p mp f p f p mp f mf

105

$ff...$

$ff...$

$ff...$

108

(#) ff

$\frac{2}{4}$ (senza rallentare!) $\frac{2}{4}$

$pp...$

$pp...$

$pp...$

Detailed description: This section of the score covers measures 108 to 112. It consists of three staves. The top staff begins with a treble clef, a key signature of one sharp (F#), and a 2/4 time signature. It contains a melodic line with eighth and sixteenth notes, including a triplet of eighth notes. The middle and bottom staves provide harmonic accompaniment with similar rhythmic patterns. Dynamic markings include fortissimo (ff) and pianissimo (pp). A tempo instruction '(senza rallentare!)' is present. Measure numbers 108, 110, and 112 are boxed at the beginning of their respective staves.

112

$\frac{3}{4}$ $ff...$

$\frac{2}{4}$

$\frac{4}{4}$ $ff...$

$ff...$

$ff...$

$ff...$

Detailed description: This section of the score covers measures 112 to 116. It consists of three staves. The top staff begins with a treble clef, a key signature of one sharp (F#), and a 3/4 time signature. It contains a melodic line with eighth and sixteenth notes, including a triplet of eighth notes and a quintuplet of eighth notes. The middle and bottom staves provide harmonic accompaniment with similar rhythmic patterns. Dynamic markings include fortissimo (ff). Measure numbers 112, 114, and 116 are boxed at the beginning of their respective staves.

116

3/4 4/4 3/4

f *f* *f*

(i) *m...* *i*

3 5 3 3 3

[dopo 5": dissolvenza lenta (in 5") fino a luce tenue di L.A, L.C, L.E]
 (A2, C2, E2 rimangono forti) rall.

120

4/4

mf *mf* *pp* *pp* *pp*

i... *i...* *m...* *m...*

3 5 3 3 3

più calmo (♩=100c.a)

124

3/4

4/4

ppp (d.)

p

pp

cedendo ancora

128

p

pp

3/4

(sim)

mp

2(c)

[dissolveva (in 3") di L.A, L.C, LE fino a zero
(A2, C2, E2 rimangono)]

subito torna
Tempo Più calmo (♩ = 100 c.a.)
mp...

132

Musical score for measures 132-135. It consists of three staves in 4/4 time. The first staff has a 5-measure phrase starting with a fermata, followed by a 3-measure phrase. The second staff has a 3-measure phrase starting with a fermata, followed by a 3-measure phrase. The third staff has a 5-measure phrase starting with a fermata, followed by a 3-measure phrase. Dynamics include mp, pp, and (pp). There are also markings for (d) and (pp) with a fermata. The score is marked with measure numbers 132, 133, 134, and 135.

stringendo

molto

[2" dopo il finale:
Buio totale]

135

Musical score for measures 135-138. It consists of three staves in 3/4 time. The first staff has a 3-measure phrase starting with a fermata, followed by a 3-measure phrase. The second staff has a 3-measure phrase starting with a fermata, followed by a 3-measure phrase. The third staff has a 3-measure phrase starting with a fermata, followed by a 3-measure phrase. Dynamics include p, mp, pp, mf, and f. There are also markings for (d) and (pp) with a fermata. The score is marked with measure numbers 135, 136, 137, and 138.

Reggio Emilia
novembre 2001